

FUNCTION TESTING

⚠ After performing any work on your firearm such as cleaning, disassembly, or installation of any accessory, check your firearm for proper functioning before firing any live ammunition.

⚠ Be sure the firearm is completely unloaded by visually and physically checking the chamber, elevator, and magazine tube. Also make certain the muzzle is pointed in a safe direction at all times.

1. Move the safety button fully rearward to the “ON” (SAFE) position.
2. Grasp the operating handle and pull the bolt fully rearward. It should lock in the open position.
3. With fingers and other objects clear of the ejection port, press the bolt release and allow the bolt to move forward under spring pressure. It should lock in the fully closed position. Repeat this procedure several times to check for free movement of the action assemblies.
4. With the action closed and the safety button fully rearward in the “ON” (SAFE) position, pull the trigger fully rearward. The hammer should not fall (NO FIRE).
5. Remove your finger from the trigger. Move the safety button forward to the “OFF” (FIRE) position. The hammer should not fall (NO FIRE).
6. Leave the safety button forward in the “OFF” (FIRE) position.
7. Pull the trigger rearward. The hammer should fall (FIRE).
8. Open the action. Move the safety button rearward to the “ON” (SAFE) position.

⚠ IF YOUR FIREARM DOES NOT PERFORM AS DESCRIBED IN ANY OF THE ABOVE STEPS, CONTACT THE FACTORY AUTHORIZED PRODUCT SERVICE CENTER IMMEDIATELY. DO NOT ATTEMPT TO USE THE FIREARM.



CHANGING BARRELS

930™ AND 935™
AUTOLOADING
SHOTGUN

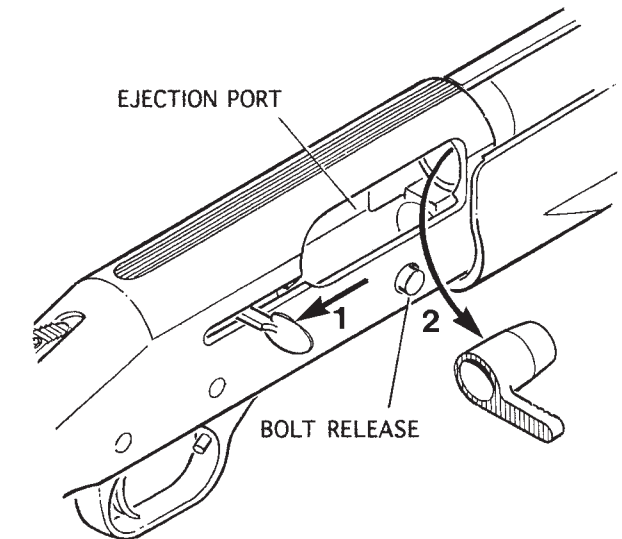

Figure 4

⚠ After performing any work on your firearm such as cleaning, disassembly, or installation of any accessory, check your firearm for proper functioning before firing any live ammunition.

⚠ Firearms are complicated mechanisms. Any modification, alteration, or improper fitting of parts may result in a dangerous malfunction, damage to the firearm and injury to the shooter and others. The firearm's owner is responsible for the correct reassembly and functioning of the firearm after any disassembly or replacement of parts.

⚠ Visually and physically inspect the chamber and bore of the barrel to make certain it is free of any obstructions, excessive oil or grease. If you are unable to remove any obstruction, bring the firearm to a qualified gunsmith or send it to a factory authorized Product Service Center. Obstructions of any kind can result in damage to the firearm and/or serious personal injury to you or those around you when the firearm is fired.

PART NO. 18973

REV A

O.F. MOSSBERG & SONS, INC.

P.O. BOX 497 • 7 GRASSO AVENUE, NORTH HAVEN, CT 06473
PHONE (800) 363-3555
www.mossberg.com

Safety and safe firearms handling is everyone's responsibility.

DISASSEMBLY



Move the safety button fully rearward to the "ON" (SAFE) position and visually and physically check the chamber, elevator, and magazine tube to be certain the firearm is unloaded before disassembling the firearm. Wear eye protection during disassembly and cleaning.

BARREL REMOVAL

The action must be in the open position (bolt fully rearward).

1. Unscrew the magazine cap (Figure 9).
2. Slide forearm forward.
3. Pull the barrel forward, free of the receiver and magazine tube.

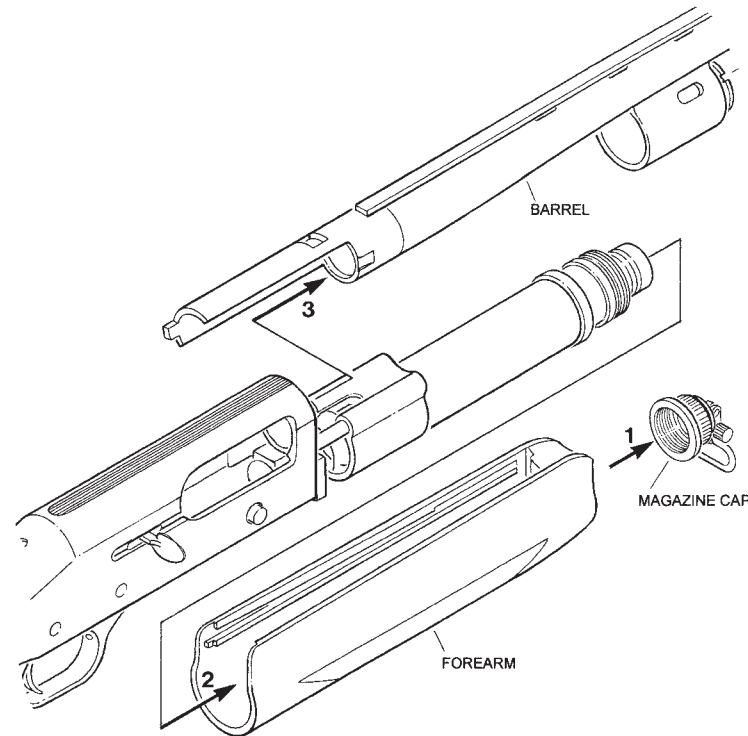
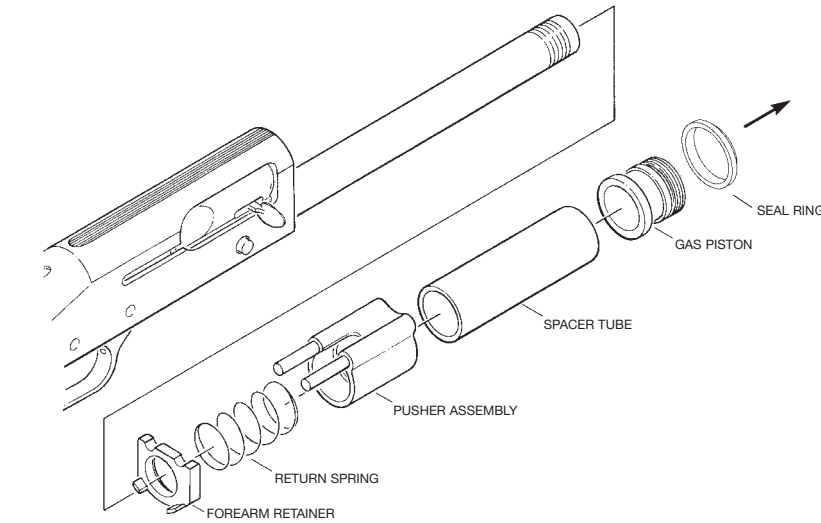

Figure 9

GAS SYSTEM REMOVAL

Remove the seal ring*, gas piston, spacer tube, pusher assembly, gas system return spring, and forearm retainer from the magazine tube (Figure 10). Note the orientation of the seal ring* for reassembly. The angled surface of the seal ring* must face outward.



*Seal ring is not used in all models

Figure 10

BARREL AND GAS SYSTEM RE-ASSEMBLY



Barrels are not interchangeable between model numbers, gauge or capacity. 930™ and 935™ model barrels are interchangeable only with barrels of the same model, gauge and capacity.

1. Grasp the operating handle and lock the action in the "OPEN" position (Figure 15).
2. Install the forearm retainer, gas system return spring, pusher assembly, spacer tube, gas piston, and seal ring* onto the magazine tube. Note the orientation of the seal ring*. Angled surface of the seal ring* must face out.



When interchanging barrels (combo models) or reinstalling the original barrel onto the firearm, YOU MUST ensure that the gas piston and seal ring* are present on the magazine tube prior to installing the barrel (see Figure 15). If the gas piston and seal ring* are not present on the magazine tube, remove them from the gas cylinder portion of the barrel that was on the firearm previously and place them onto the magazine tube as shown in Figure 15. Failure to do so may result in a dangerous malfunction, damage to the firearm and injury to the shooter and other persons. The firearm's owner must accept full responsibility for the correct reassembly and functioning of the firearm after any disassembly or replacement of parts.

3. Install the barrel into the receiver and over the magazine tube. Continue to push the barrel into the receiver until fully seated. If the barrel binds during assembly, slide the gas piston forward, towards the gas cylinder. This should allow the barrel to seat.

4. Install the forearm.

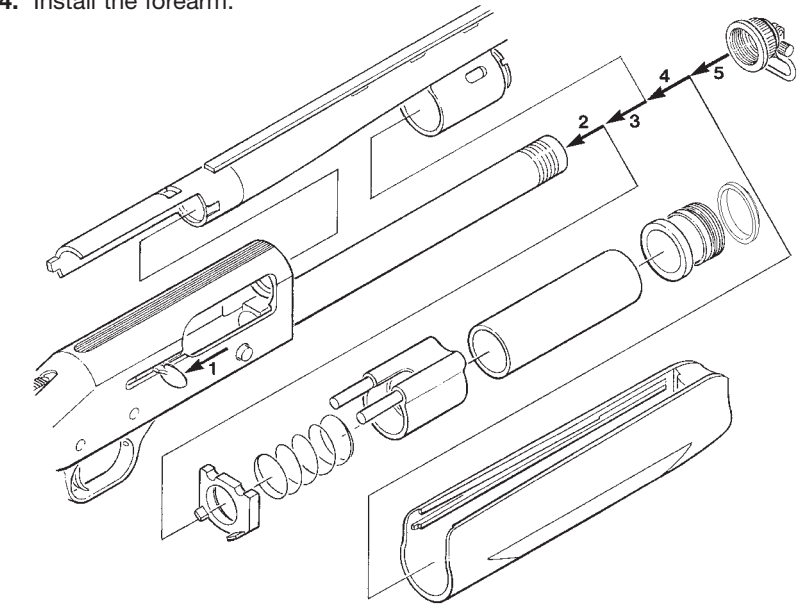

Figure 15

*Seal ring is not used in all models

5. Install magazine cap. Tighten cap hand-tight only.